

RAPID PRO LRP

Technik im Detail / Geräteabmessungen

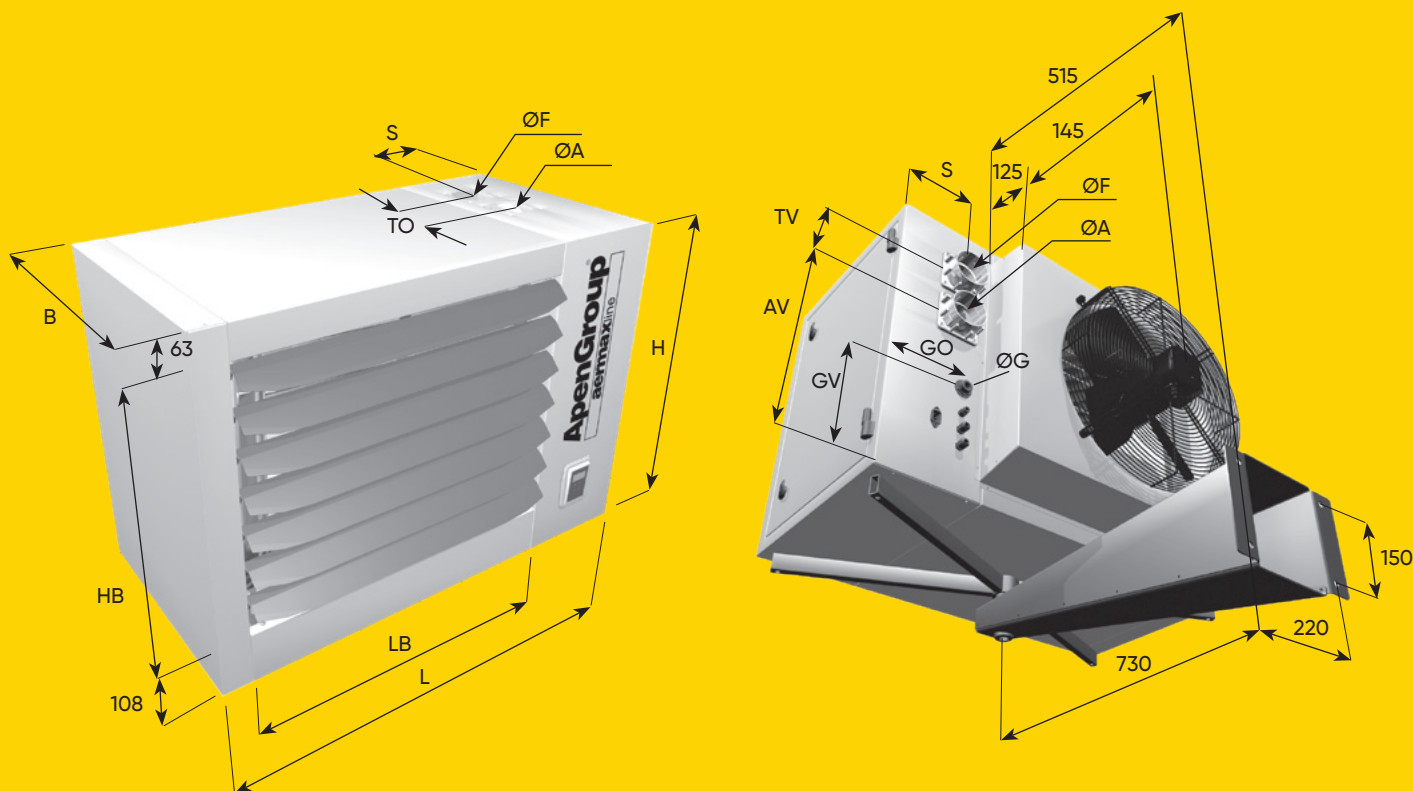

RAPID PRO

Model	Abmessungen			Lamellen		Klammern		GAS-Anschluss			Verpackung			
	B	H	L	HB	LB	IS	ID	ØG	GO	GV	Bi	Li	Hi	Hbi
LRP018 LRP028	500	690	795	520	490	395	400	3/4"	180	255	815	1065	870	850
LRP035 LRP045			985		680	490	495						1065	
LRP055		765	595	1010	605	710	920							
LRP075			1310	605	710	1395								
LRP102		845	1515	675	1180	720	795						210	275